



FCR XL-2 & FCR XC-2

Digital X-ray with Exceptional Image Quality for Private Practitioners in an Efficient, Compact Package

Application

The Fujifilm Computed Radiography (FCR) XL-2 and XC-2 are digital radiography systems utilizing storage phosphor Imaging Plates (IP) as an x-ray detection device.

FCR XL-2 and XC-2 units scan and process x-ray image information from an IP that has been exposed using a cassette-type x-ray stand. This system can also print out hard copies on film via a connected image recorder and can transmit digital images to PACS.

The FCR XL-2 and XC-2 provides general x-ray imaging for Private Practitioners. FCR XL-2 and XC-2 systems also include the capability to perform Pantomographic exams.

Features

Due to the benefits of digital image processing, the system produces radiographs that have a high diagnostic value and are easy to read. Fast Scan (200 μ), Standard High Resolution (100 μ) and High Resolution (50 μ) size using HR IP's is possible with the FCR XL-2.

Reading modes are user selectable. Fast Scan reading provides maximum throughput for the XL-2 for both 14x14" and 14x17" sizes, while standard HQ reading mode provides 10 pixel/mm resolution image acquisition and display for all intake sizes without impacting system speed.

High Resolution (50 μ) Scanning is available with the FCR XL-2 for 18x24cm and 24x30cm sized (HR IP's) making it ideal for orthopedic and extremity applications, where seeing fine detail is critical.

The system's wide latitude and automatic sensitivity adjustment function protects radiographs from variations in x-ray exposure conditions. This results in consistent image density for all types of radiographs. Image processing parameters are selected through anatomical region selection menus.

The FCR XL-2 reader can be network connected to multiple Flash IIP (Image & Information Processor) consoles and other FCR readers for maximum scalability and redundancy.

The FCR XC-2 supports a dedicated relationship of the reader to the Flash IIP console workstation.

A Flash IIP console workstation is provided standard with each reader unit. Fujifilm's Flash IIP is designed for simple and fast patient identification, image viewing, reprocessing and optimization. It integrates patient identification process (via manual entry or automated by connection with RIS/HIS using DICOM Worklist Management) with Fujifilm's intelligent image processing and ability to transmit images to PACS and/or imagers. The Flash IIP features a simplified user interface, which allows for complete patient processing in as few as 3 easy steps. See Flash IIP datasheet for more information.

Options

Dedicated XL-2, XC-2 cart: Heavy duty engineered stand providing countertop and cassette holder space for the reader, with the CPU and monitor of the Flash IIP console.

Other System Components

Flash IIP consoles
 Flash IIP Laptop
 FCR External DVD-RW
 Custom Stand
 Seismic Brackets
 Mobile Kit
 Axon (Sold Separately)

Available IP Cassette Types

Inch settings
 14 x 17", 14 x 14", 10 x 12", 8 x 10",
 14 x 34", 14 x 40", 14 x 50", 15 x 30cm
 Metric settings
 35 x 43cm, 35 x 35cm, 24 x 30cm,
 18 x 24cm, 15 x 30cm

Mobile kit

Hardware brackets to stabilize & support for mobile vehicle use.
 Optional FCR XL-2 and XC-2 Laptop
 Flash IIP console also available to reduce space requirements.

FCR XL-2 Image Reader (Model: CR IR 359 RU2E) & FCR XC-2 Image Reader (Model: CR IR 357 RU2E)

- (1) IP cassette type CC, LC, PC
- (2) Flash IIP Console
- (3) Image Recorder:
 DRYPIX 2000, DRYPIX 4000
 DRYPIX 5000

Supplies

Fujifilm Imaging Plates (IP)

Standard type ST-VI
 14 x 17" (35 x 43cm), 14 x 14"
 (35 x 35cm), 10 x 12", 8 x 10",
 24 x 30cm, 18 x 24cm,
 15 x 30cm
 HR-V (FCR XL-2 Only)
 24 x 30cm, 18 x 24cm

Throughput (IP/hour)

IP/Cassette Size	XL-2		XC-2
	Fast Scan (5pixels/mm)	Standard HQ (10pixels/mm)	Standard HQ (10pixels/mm)
14x17in	87	62	43
14x14in	94	70	50
10x12in	-	73	54
8x10in	-	87	67
24x30cm	-	75	54
18x24cm	-	92	72
15x30cm	-	73	55

Cycle Time (Sec.)

XL-2			XC-2
Standard HQ	Fast Scan	HR-V	Standard HQ
58	41	-	82
52	38	-	72
49	-	-	66
41	-	-	53
48	-	59	66
39	-	51	50
49	-	-	65

IMAGE READING

Reading gray scale: 12 bits/pixel

Output gray scale: 10 or 12 bits/pixel

FCR XL-2 Sampling Rate

Reading Size		14x17cm	14x14cm	10x12cm	8x10cm	24x30cm	18x24cm	HR-V 24x30cm	HR-V 18x24cm	15x30cm
Fast Scan Pixel density	Pixel Density (pixels / mm)	5	5	-	-	-	-	-	-	-
	Number of Pixels	1760x2140	1760x1760	-	-	-	-	-	-	-
High Pixel density	Pixel Density (pixels / mm)	10	10	10	10	10	10	20	20	10
	Number of Pixels	3520x4280	3520x3520	2505x3015	2000x2510	2364x2964	1770x2370	4728x5928	3540x4740	1464x2964

FCR XC-2 Sampling Rate

Reading Size		14x17"	14x14"	10x12"	8x10"	24x30cm	18x24cm	15x30cm
Pixel density	Pixel Density (pixels / mm)	10	10	10	10	10	10	10
	Number of Pixels	3520x4280	3520x3520	2505x3015	2000x2510	2364x2964	2364x2964	1464x2964

EXTERNAL DIMENSIONS AND WEIGHT*:

Power Supply Conditions

Single phase 50–60Hz
 AC 120–240V ±10%
 5A (Max.)

Operating Conditions

Temperature: 15 - 30°C
 Humidity: 40 - 80%RH
 (No dew condensation)

Heat Output:
 XL-995 BTU/hr
 XC-692 BTU/hr

Power consumption:
 XL-290 VA (W) or less
 XC-200 VA (W) or less

Width in. (mm)	Depth in. (mm)	Height in. (mm)	Weight lb. (kg)
23.25 (590)	15 (380)	32 (810)	218 (99)

* Dimensions and weight are approximate and are subject to change without prior notice.

FCR XL-2/XC-2 Image Reader

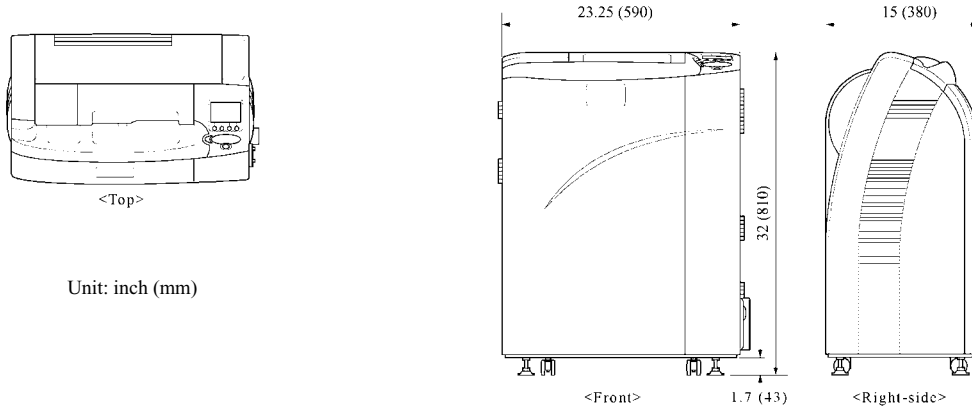

Unit: inch (mm)

Footprint For Placement

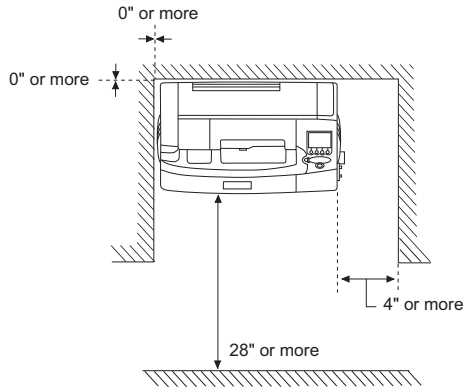

Installations Without Floor Anchoring

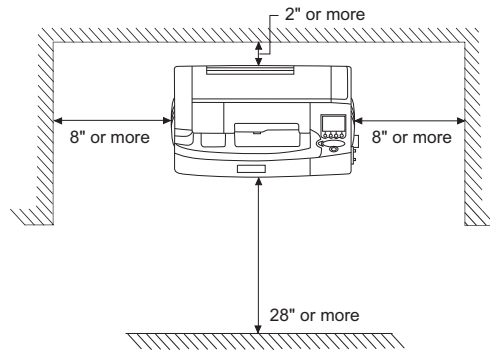

Seismic & Vehicle Mounted Installations
 Need 52" Minimum Height

Cart Dimensions

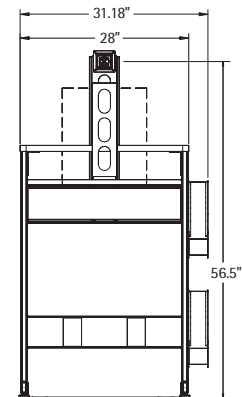
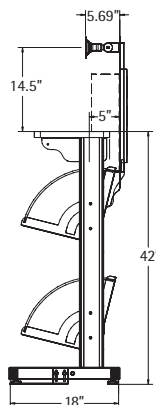
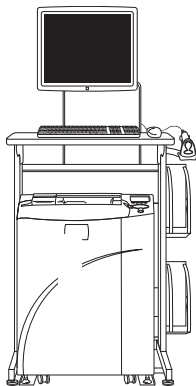

Connectivity Diagram for Typical Practice

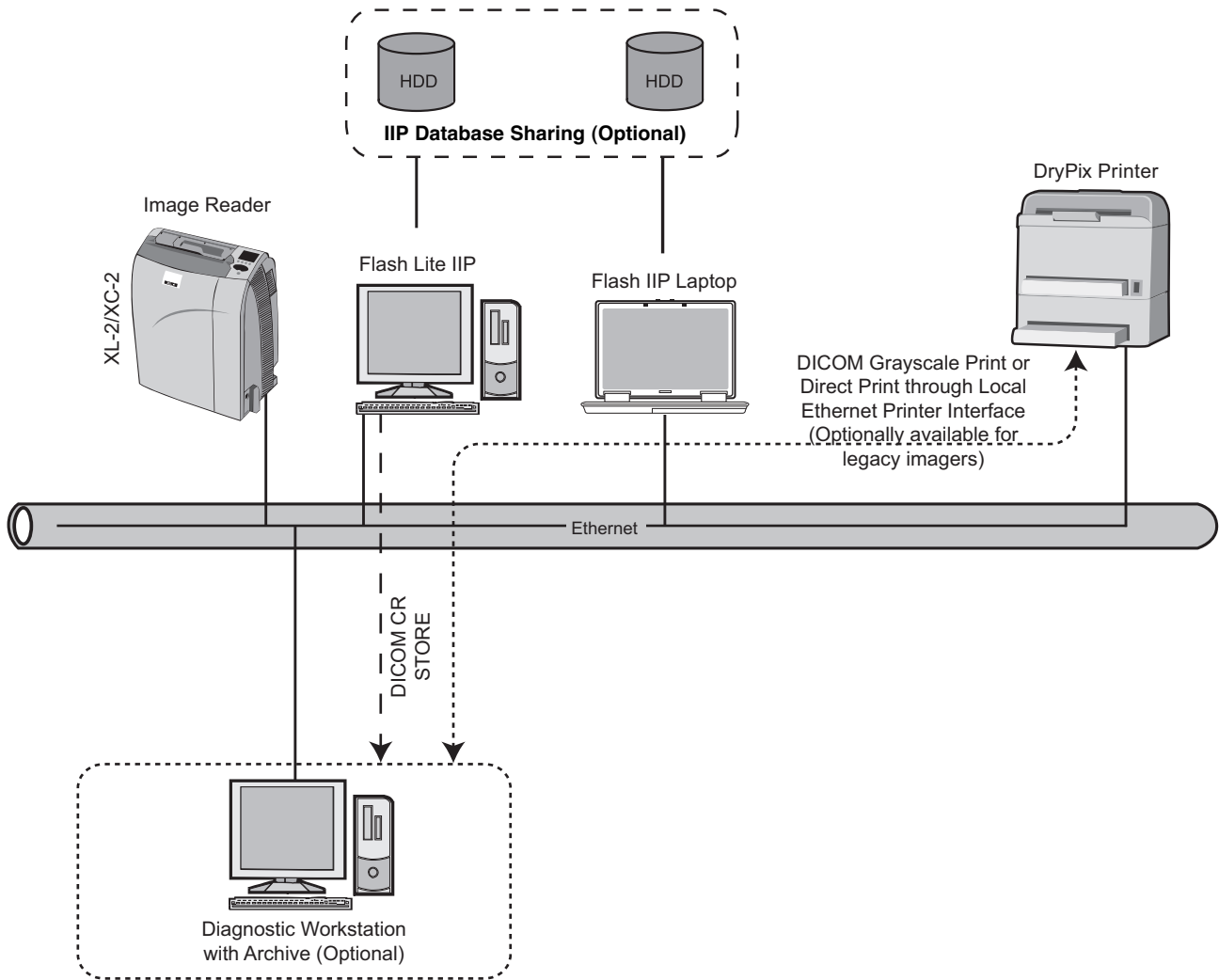

Notes:

- Network Interface - 100 Base-T, half or full recommended.
- Interface to other FCR Readers and/or Flash IIPs on the network.
- Any FCR Reader can be utilized after registering the patient at a Flash IIP connected to the same network.
- Database Sharing (option) allows sharing exam and image data between Flash IIP Consoles within Database Sharing cluster.
- Interfacing with Legacy FCR equipment - devices that communicate through DMS protocol can be connected to the network printer by adding an optional Fujifilm DryPix Station to convert the DMS to DICOM.

Specifications subject to change without notice.

Authorized Fujifilm Dealer:

FUJIFILM Medical Systems USA, Inc.

Corporate Headquarters

419 West Avenue
Stamford, CT 06902-6348
203-324-2000
800-431-1850

1055 Stevenson Court
Roselle, IL 60172-2300
630-582-2202
800-323-2546

29012 N. Hancock Parkway
Building 7
Valencia, CA 91355-1007
866-533-FUJI (3854)

www.fujimed.com

Essential Enterprise Solutions, Inc.
3686 Old Keystone Rd.
Tarpon Springs FL 34688
727-938-3374 Office
727-499-7814 FAX